

Hubkrafttabellen EW100



Abb. 1: Hubkrafttabelle EW100 - Monoausleger



Abb. 2: Hubkrafttabelle EW100 - Verstellausleger

max	Zulässige Last bei gestrecktem Löffelstiel
A	Ausladung von mitte Drehkranz
B	Lasthakenhöhe
*	Hubkraft durch Hydraulik begrenzt

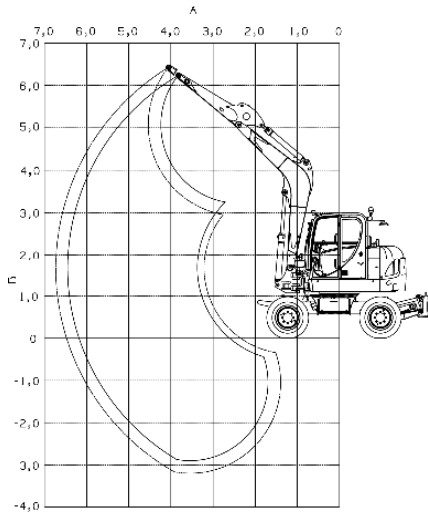
Alle Tabellenwerte sind in kg (lbs) angegeben, bei waagrechtter Stellung auf festem Untergrund und ohne Löffel oder einem Arbeitsgerät.

- I Fahrzeug gegen Fahrtrichtung mit Planierschild- oder Prätzenabstützung, Kippung durch Planierschild oder Prätzen
- II Fahrzeug gegen Fahrtrichtung ohne Planierschild- oder Prätzenabstützung, Kippung durch Hinterachse
- III Fahrzeug in Fahrtrichtung ohne Planierschild- oder Prätzenabstützung, Kippung durch Vorderachse
- IV Fahrzeug 90° zur Fahrtrichtung ohne Planierschild- oder Prätzenabstützung

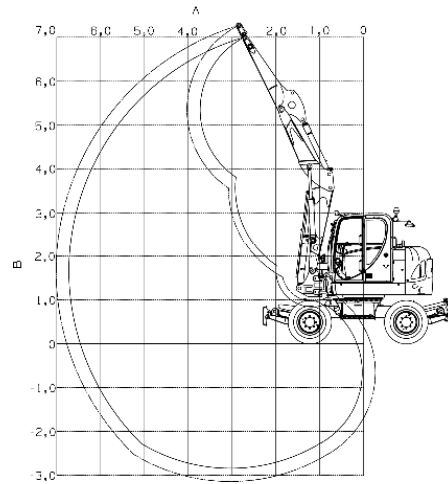
Die Hubkraft des Fahrzeugs ist durch die Einstellung der Überdruckventile und hydraulische Leistung bzw. durch die Kippsicherheit begrenzt.

Es werden weder 75% der statischen Kipplast noch 87% der hydraulischen Hubkraft überschritten.

Berechnungsgrundlage: gemäß ISO 10567. Einstelldruck am Hubarmzylinder 29000 kPA (4206 psi).

Die Hubfähigkeit gilt für Fahrzeuge unter folgenden Bedingungen:

- Schmier- und Betriebsmittel auf den vorgeschriebenen Ständen.
- Voller Kraftstofftank.
- Kabine.
- Fahrzeug auf Betriebstemperatur.
- Gewicht des Fahrers 75 kg (165 lbs).

Hubkrafttabellen EW100 - Monoausleger

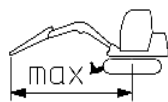
A \ B	4 m (13'-1")				5 m (16'-5")				6 m (19'-8")							
	I	II	III	IV	I	II	III	IV	I	II	III	IV	I	II	III	IV
6,0 m (19.7 ft)	2014* (4440)*	2014* (4440)*	2014* (4440)*	2014* (4440)*	-	-	-	-	-	-	-	-	2039* (4495)*	2039* (4495)*	2039* (4495)*	2039* (4495)*
4,5 m (14.8 ft)	-	-	-	-	1815* (4001)*	1521 (3353)	1815* (4001)*	1616 (3563)	-	-	-	-	1823* (4019)*	1236 (2725)	1823* (4019)*	1312 (2892)
3,0 m (9.8 ft)	2485* (5478)*	2053 (4526)	2485* (5478)*	2201 (4852)	2046* (4511)*	1452 (3201)	2046* (4511)*	1545 (3406)	1827* (4028)*	1083 (2388)	1695 (3737)	1149 (2533)	1847* (4072)*	1046 (2306)	1621 (3574)	1107 (2441)
1,5 m (4.9 ft)	3260* (7187)*	1842 (4061)	2989 (6590)	1982 (4370)	2399* (5289)*	1347 (2970)	2145 (4729)	1438 (3170)	1959* (4319)	1034 (2280)	1643 (3622)	1099 (2423)	1817* (4006)*	926 (2041)	1476 (3254)	984 (2169)
0,0 m (0.0 ft)	3438* (7579)*	1742 (3840)	2879 (6347)	1878 (4140)	2525* (5567)*	1279 (2820)	2072 (4568)	1368 (3016)	1951* (4301)*	998 (2200)	1605 (3538)	1063 (2344)	1846* (4070)*	959 (2114)	1541 (3397)	1021 (2251)
-1,0 m (-3.3 ft)	3190* (7033)*	1735 (3825)	2872 (6332)	1872 (4127)	2359* (5201)*	1268 (2795)	2061 (4544)	1357 (2992)	-	-	-	-	1853* (4085)	1062 (2341)	1710 (3770)	1132 (2496)

Tab 1: Hubkrafttabelle EW100 – Monoausleger, Zwillingbereifung, Planierschild hinten, kurzer Löffelstiel

A \ B	4 m (13'-1")				5 m (16'-5")				6 m (19'-8")							
	I	II	III	IV	I	II	III	IV	I	II	III	IV	I	II	III	IV
6,0 m (19.7 ft)	-	-	-	-	-	-	-	-	-	-	-	-	1824* (4021)*	1724 (3801)	1824* (4021)*	1824* (4021)*
4,5 m (14.8 ft)	-	-	-	-	1662* (3664)*	1540 (3395)	1662* (3664)	1636 (3607)	-	-	-	-	1685* (3715)*	1128 (2487)	1685* (3715)*	1196 (2637)
3,0 m (9.8 ft)	2274* (5013)	2087 (4601)	2274* (5013)*	2236 (4930)	1919* (4231)*	1464 (3228)	1919* (4231)*	1558 (3435)	1729* (3812)*	1088 (2399)	1702 (3752)	1155 (2546)	1672* (3686)	929 (2048)	1468 (3236)	986 (2174)
1,5 m (4.9 ft)	3115* (6867)*	1860 (4101)	3011 (6638)	2002 (4414)	2310* (5093)*	1351 (2978)	2150 (4740)	1442 (3180)	1899* (4187)*	1030 (2271)	1640 (3616)	1096 (2416)	1698* (3743)*	861 (1898)	1380 (3042)	915 (2017)
0,0 m (0.0 ft)	3435* (7573)*	1733 (3821)	2871 (6329)	1870 (4123)	2508* (5529)*	1269 (2798)	2063 (4548)	1358 (2994)	1961* (4323)*	985 (2172)	1592 (3510)	1049 (2313)	1738* (3832)*	886 (1953)	1431 (3155)	943 (2079)
-1,0 m (-3.3 ft)	3276* (7222)*	1711 (3772)	2848 (6279)	1848 (4074)	2415* (5324)*	1249 (2754)	2042 (4502)	1338 (2950)	1794* (3955)*	980 (2161)	1587 (3499)	1044 (2302)	1755* (3869)*	968 (2134)	1568 (3457)	1032 (2275)

Tab 2: Hubkrafttabelle EW100 – Monoausleger, Zwillingbereifung, Planierschild hinten, langer Löffelstiel

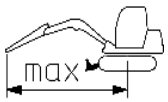
A \ B	4 m (13'-1")				5 m (16'-5")				6 m (19'-8")							
	I	II	III	IV	I	II	III	IV	I	II	III	IV	I	II	III	IV
6,0 m (19.7 ft)	2014* (4440)*	2014* (4440)*	2014* (4440)*	2014* (4440)*	-	-	-	-	-	-	-	-	2039* (4495)*	1962 (4325)	2039* (4495)*	2039* (4495)*
4,5 m (14.8 ft)	-	-	-	-	1815* (4001)*	1461 (3221)	1815* (4001)*	1555 (3428)	-	-	-	-	1823* (4019)*	1184 (2610)	1823* (4019)*	1260 (2778)
3,0 m (9.8 ft)	2485* (5478)*	1972 (4348)	2485* (5478)*	2119 (4672)	2046* (4511)*	1391 (3067)	2046* (4511)*	1484 (3272)	1827* (4028)*	1035 (2282)	1644 (3624)	1101 (2427)	1847* (4072)*	1000 (2205)	1573 (3468)	1062 (2341)
1,5 m (4.9 ft)	3260* (7187)*	1761 (3882)	2900 (6393)	1900 (4189)	2399* (5289)	1287 (2837)	2080 (4586)	1377 (3036)	1959* (4319)*	985 (2172)	1592 (3510)	1051 (2317)	1817* (4006)*	882 (1944)	1430 (3153)	940 (2072)
0,0 m (0.0 ft)	3438* (7579)*	1660 (3660)	2789 (6149)	1796 (3960)	2525* (5567)*	1218 (2685)	2007 (4425)	1307 (2881)	1951* (4301)*	950 (2094)	1554 (3426)	1015 (2238)	1849* (4076)*	913 (2013)	1492 (3289)	974 (2147)
-1,0 m (-3.3 ft)	3190* (7033)*	1654 (3646)	2782 (6133)	1789 (3944)	2359* (5201)*	1208 (2663)	1996 (4400)	1296 (2857)	-	-	-	-	1853* (4085)*	1011 (2229)	1656 (3651)	1081 (2383)

Tab 3: Hubkrafttabelle EW100 – Monoausleger, Ballonbereifung, Planierschild hinten, kurzer Löffelstiel

Hubkrafttabellen EW100 - Monoausleger

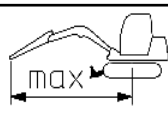
A \ B	4 m (13'-1")				5 m (16'-5")				6 m (19'-8")							
	I	II	III	IV	I	II	III	IV	I	II	III	IV	I	II	III	IV
6,0 m (19.7 ft)	-	-	-	-	-	-	-	-	-	-	-	-	1824*	1657	1824*	1768
													(4021)*	(3653)	(4021)*	(3898)
4,5 m (14.8 ft)	-	-	-	-	1662*	1479	1662*	1575	-	-	-	-	1685*	1079	1685*	1148
					(3664)*	(3261)	(3664)*	(3472)					(3715)*	(2379)	(3715)*	(2531)
3,0 m (9.8 ft)	2274*	2005	2274*	2154	1919*	1404	1919*	1498	1729*	1040	1651	1107	1672*	886	1422	943
	(5013)*	(4420)	(5013)*	(4749)	(4231)*	(3095)	(4231)*	(3303)	(3812)*	(2293)	(3640)	(2441)	(3686)*	(1953)	(3135)	(2079)
1,5 m (4.9 ft)	3115*	1779	2922	1919	2310*	1290	2085	1381	1899*	982	1589	1048	1698*	819	1336	873
	(6867)*	(3922)	(6442)	(4231)	(5093)*	(2844)	(4597)	(3045)	(4187)*	(2165)	(3503)	(2310)	(3743)*	(1806)	(2945)	(1925)
0,0 m (0.0 ft)	3435*	1651	2782	1787	2508*	1208	1998	1297	1961*	937	1541	1001	1738*	842	1385	899
	(7573)*	(3640)	(6133)	(3940)	(5529)*	(2663)	(4405)	(2859)	(4323)*	(2066)	(3397)	(2207)	(3832)*	(1856)	(3053)	(1982)
-1,0 m (-3.3 ft)	3276*	1630	2758	1765	2415*	1189	1977	1277	1794*	931	1536	996	1755*	921	1517	984
	(7222)*	(3594)	(6080)	(3891)	(5324)*	(2621)	(4359)	(2815)	(3955)*	(2053)	(3386)	(2196)	(3869)*	(2030)	(3344)	(2169)

Tab 4: Hubkrafttabelle EW100 – Monoausleger, Ballonbereifung, Planierschild hinten, langer Löffelstiel

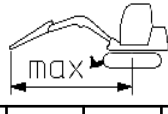
A \ B	4 m (13'-1")				5 m (16'-5")				6 m (19'-8")							
	I	II	III	IV	I	II	III	IV	I	II	III	IV	I	II	III	IV
6,0 m (19.7 ft)	2014*	2014*	2014*	2014*	-	-	-	-	-	-	-	-	2039*	2039*	2039*	2039*
	(4440)*	(4440)*	(4440)*	(4440)*									(4495)*	(4495)*	(4495)*	(4495)*
4,5 m (14.8 ft)	-	-	-	-	1815*	1761	1815*	1718	-	-	-	-	1823*	1444	1823*	1400
					(4001)*	(3882)	(4001)*	(3788)					(4019)*	(3183)	(4019)*	(3086)
3,0 m (9.8 ft)	2485*	2375	2485*	2340	2046*	1692	2046*	1647	1827*	1274	1645	1230	1847*	1226	1574	1184
	(5478)*	(5236)	(5478)*	(5159)	(4511)*	(3730)	(4511)*	(3631)	(4028)*	(2809)	(3627)	(2712)	(4072)*	(2703)	(3470)	(2610)
1,5 m (4.9 ft)	3260*	2164	2903	2121	2399*	1587	2083	1540	1959*	1225	1593	1180	1817*	1101	1431	1058
	(7187)*	(4771)	(6400)	(4676)	(5289)*	(3499)	(4592)	(3395)	(3516)*	(2701)	(3512)	(2601)	(4006)*	(2427)	(3155)	(2332)
0,0 m (0.0 ft)	3438*	2064	2793	2017	2525*	1519	2009	1470	1951*	1189	1556	1144	1849*	1143	1494	1099
	(7580)*	(4550)	(6158)	(4447)	(5567)*	(3349)	(4429)	(3241)	(4301)*	(2621)	(3430)	(2522)	(4076)*	(2520)	(3294)	(2423)
-1,0 m (-3.3 ft)	3190*	2057	2785	2010	2359*	1508	1998	1459	-	-	-	-	1853*	1264	1657	1218
	(7033)*	(4535)	(6140)	(4431)	(5201)*	(3325)	(4405)	(3217)					(4085)*	(2787)	(3653)	(2685)

Tab 5: Hubkrafttabelle EW100 – Monoausleger, Zwillingbereifung, Planierschild hinten, Prätzen vorne, kurzer Löffelstiel

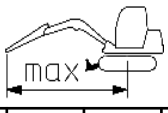
A \ B	4 m (13'-1")				5 m (16'-5")				6 m (19'-8")							
	I	II	III	IV	I	II	III	IV	I	II	III	IV	I	II	III	IV
6,0 m (19.7 ft)	-	-	-	-	-	-	-	-	-	-	-	-	1824*	1824*	1824*	1824*
													(4021)*	(4021)*	(4021)*	(4021)*
4,5 m (14.8 ft)	-	-	-	-	1662*	1662*	1662*	1662*	-	-	-	-	1685*	1321	1685*	1278
					(3664)*	(3664)*	(3664)*	(3664)					(3715)*	(2912)	(3715)*	(2818)
3,0 m (9.8 ft)	2274*	2274*	2274*	2274*	1919*	1704	1919*	1661	1729*	1279	1652	1236	1672*	1100	1424	1058
	(5013)*	(5013)*	(5013)*	(5013)*	(4231)*	(3757)	(4231)*	(3662)	(3812)*	(2820)	(3642)	(2725)	(3686)*	(2425)	(3140)	(2332)
1,5 m (4.9 ft)	3115*	2182	2925	2140	2310*	1590	2088	1544	1899*	1221	1591	1177	1698*	1027	1338	985
	(6867)*	(4810)	(6449)	(4718)	(5093)*	(3505)	(4603)	(3404)	(4187)*	(2692)	(3506)	(2595)	(3743)*	(2264)	(2950)	(2172)
0,0 m (0.0 ft)	3435*	2055	2785	2008	2508*	1509	2000	1460	1961*	1176	1543	1131	1738*	1060	1387	1016
	(7573)*	(4530)	(6140)	(4427)	(5529)*	(3327)	(4409)	(3219)	(4323)*	(2593)	(3402)	(2493)	(3832)*	(2337)	(3058)	(2240)
-1,0 m (-3.3 ft)	3276*	2033	2761	1986	2415*	1489	1979	1440	1794*	1171	1538	1125	1755*	1157	1519	1112
	(7222)*	(4482)	(6087)	(4378)	(5324)*	(3283)	(4363)	(3175)	(3955)*	(2582)	(3391)	(2480)	(3869)*	(2551)	(3349)	(2452)

Tab 6: Hubkrafttabelle EW100 – Monoausleger, Zwillingbereifung, Planierschild hinten, Prätzen vorne, Langer Löffelstiel

Hubkrafttabellen EW100 - Monoausleger

A \ B	4 m (13'-1")				5 m (16'-5")				6 m (19'-8")							
	I	II	III	IV	I	II	III	IV	I	II	III	IV	I	II	III	IV
6,0 m (19.7 ft)	2014* (4440)*	2014* (4440)*	2014* (4440)*	2014* (4440)*	-	-	-	-	-	-	-	-	2039* (4495)*	2039* (4495)*	2039* (4495)*	2039* (4495)*
4,5 m (14.8 ft)	-	-	-	-	1815* (4001)*	1700 (3748)	1815* (4001)*	1658 (3655)	-	-	-	-	1823* (4019)*	1391 (3067)	1803 (3975)	1348 (2972)
3,0 m (9.8 ft)	2485* (5478)*	2294 (5057)	2485* (5478)*	2257 (4976)	2046* (4511)*	1631 (3596)	2046* (4511)*	1587 (3499)	1827* (4028)*	1226 (2703)	1595 (3516)	1182 (2606)	1857* (4094)*	1181 (2604)	1526 (3364)	1139 (2511)
1,5 m (4.9 ft)	3260* (7187)*	2083 (4592)	2814 (6204)	2039 (4495)	2399* (5289)*	1527 (3366)	2018 (4449)	1480 (3263)	1959* (4319)*	1176 (2593)	1542 (3399)	1132 (2496)	1817* (4006)*	1057 (2330)	1385 (3053)	1014 (2235)
0,0 m (0.0 ft)	3438* (7579)*	1982 (4370)	2703 (5959)	1935 (4266)	2525* (5567)*	1458 (3214)	1944 (4286)	1409 (3106)	1951* (4301)*	1141 (2515)	1505 (3318)	1096 (2416)	1849* (4076)*	1097 (2418)	1445 (3186)	1052 (2319)
-1,0 m (-3.3 ft)	3190* (7033)*	1976 (4356)	2696 (5944)	1928 (4251)	2359* (5201)*	1448 (3192)	1933 (4262)	1399 (3084)	-	-	-	-	1853* (4085)*	1213 (2674)	1603 (3534)	1167 (2573)

Tab 7: Hubkrafttabelle EW100 – Monoausleger, Ballonbereifung, Pratzten vorne, Planierschild hinten, kurzer Löffelstiel

A \ B	4 m (13'-1")				5 m (16'-5")				6 m (19'-8")							
	I	II	III	IV	I	II	III	IV	I	II	III	IV	I	II	III	IV
6,0 m (19.7 ft)	-	-	-	-	-	-	-	-	-	-	-	-	1824* (4021)*	1824* (4021)*	1824* (4021)*	1824* (4021)*
4,5 m (14.8 ft)	-	-	-	-	1662* (3664)*	1662* (3664)*	1662* (3664)*	1662* (3664)*	-	-	-	-	1685* (3715)*	1272 (2804)	1649 (3635)	1230 (2712)
3,0 m (9.8 ft)	2274* (5013)*	2274* (5013)*	2274* (5013)*	2274* (5013)*	1919* (4231)*	1643 (3622)	1919* (4231)*	1600 (3527)	1729* (3812)*	1231 (2714)	1601 (3530)	1188 (2619)	1672* (3686)*	1057 (2330)	1378 (3038)	1015 (2238)
1,5 m (4.9 ft)	3115* (6867)*	2101 (4632)	2835 (6250)	2058 (4537)	2310* (5093)*	1530 (3373)	2023 (4460)	1483 (3269)	1899* (4187)*	1173 (2586)	1540 (3395)	1129 (2489)	1698* (3743)*	985 (2172)	1294 (2853)	944 (2081)
0,0 m (0.0 ft)	3435* (7573)*	1973 (4350)	2695 (5941)	1926 (4246)	2508* (5529)*	1448 (3192)	1935 (4266)	1400 (3086)	1961* (4323)*	1128 (2487)	1492 (3289)	1082 (2385)	1738* (3832)*	1016 (2240)	1341 (2956)	973 (2145)
-1,0 m (-3.3 ft)	3276* (7222)*	1952 (4303)	2672 (5891)	1904 (4198)	2415* (5324)*	1429 (3150)	1914 (4220)	1380 (3042)	1794* (3955)*	1122 (2474)	1487 (3278)	1077 (2374)	1755* (3869)*	1110 (2447)	1469 (3239)	1065 (2348)

Tab 8: Hubkrafttabelle EW100 – Monoausleger, Ballonbereifung, Pratzten vorne, Planierschild hinten, langer Löffelstiel

A \ B	4 m (13'-1")				5 m (16'-5")				6 m (19'-8")							
	I	II	III	IV	I	II	III	IV	I	II	III	IV	I	II	III	IV
6,0 m (19.7 ft)	2014* (4440)*	2014* (4440)*	2014* (4440)*	2014* (4440)*	-	-	-	-	-	-	-	-	2039* (4495)*	2039* (4495)*	2039* (4495)*	2039* (4495)*
4,5 m (14.8 ft)	-	-	-	-	1815* (4001)*	1574 (3470)	1815* (4001)*	1557 (3433)	-	-	-	-	1823 (4019)	1282 (2826)	1740 (3836)	1261 (2780)
3,0 m (9.8 ft)	2485* (5478)*	2125 (4684)	2485* (5478)*	2121 (4676)	2046* (4511)*	1505 (3318)	2046* (4511)*	1486 (3276)	1827* (4028)*	1125 (2480)	1536 (3386)	1103 (2432)	1847* (4072)*	1085 (2392)	1471 (3243)	1063 (2344)
1,5 m (4.9 ft)	3260* (7187)*	1913 (4217)	2711 (5977)	1902 (4193)	2399* (5289)*	1400 (3086)	1943 (4284)	1379 (3040)	1959* (4319)*	1076 (2372)	1484 (3272)	1052 (2319)	1817* (4006)*	965 (2127)	1332 (2937)	941 (2075)
0,0 m (0.0 ft)	3438* (7579)*	1813 (3997)	2601 (5734)	1798 (3964)	2525* (5567)*	1332 (2937)	1870 (4123)	1309 (2886)	1951* (4301)*	1040 (2293)	1447 (3190)	1016 (2240)	1849* (4076)*	1000 (2205)	1389 (3062)	975 (2150)
-1,0 m (-3.3 ft)	3190* (7033)*	1806 (3982)	2594 (5719)	1792 (3951)	2359* (5201)*	1321 (2912)	1859 (4098)	1298 (2862)	-	-	-	-	1853* (4085)*	1107 (2441)	1542 (3400)	1082 (2385)

Tab 9: Hubkrafttabelle EW100 – Monoausleger, Zwillingsbereifung, Pratzten hinten, kurzer Löffelstiel

Hubkrafttabellen EW100 - Monoausleger

A \ B	4 m (13'-1")				5 m (16'-5")				6 m (19'-8")							
	I	II	III	IV	I	II	III	IV	I	II	III	IV	I	II	III	IV
6,0 m (19.7 ft)	-	-	-	-	-	-	-	-	-	-	-	-	1824*	1782	1824*	1770
	-	-	-	-	-	-	-	-	-	-	-	-	(4021)*	(3929)	(4021)*	(3902)
4,5 m (14.8 ft)	-	-	-	-	1662*	1593	1662*	1577	-	-	-	-	1685*	1171	1590	1149
	-	-	-	-	(3664)*	(3512)	(3664)	(3477)	-	-	-	-	(3715)*	(2582)	(3505)	(2533)
3,0 m (9.8 ft)	2274*	2158	2274*	2156	1919*	1517	1919*	1499	1729*	1130	1543	1108	1672*	967	1326	944
	(5013)*	(4758)	(5013)*	(4753)	(4231)*	(3344)	(4231)*	(3305)	(3812)*	(2491)	(3402)	(2443)	(3686)*	(2132)*	(2923)	(2081)
1,5 m (4.9 ft)	3115*	1931	2733	1922	2310*	1403	1948	1383	1899*	1072	1482	1049	1698*	898	1243	874
	(6867)*	(4257)	(6025)	(4237)	(5093)*	(3093)	(4295)	(3049)	(4187)*	(2363)	(3267)	(2313)	(3743)*	(1980)	(2740)	(1927)
0,0 m (0.0 ft)	3435*	1804	2593	1790	2508*	1322	1861	1299	1961*	1027	1434	1003	1738*	924	1288	900
	(7573)*	(3977)	(5717)	(3946)	(5529)*	(2915)	(4103)	(2864)	(4323)*	(2264)	(3161)	(2211)	(3832)*	(2037)	(2840)	(1984)
-1,0 m (-3.3 ft)	3276*	1783	2570	1768	2415*	1302	1840	1279	1794*	1022	1428	997	1755*	1010	1411	986
	(7222)*	(3931)	(5666)	(3898)	(5324)*	(2870)	(4057)	(2820)	(3955)*	(2253)	(3148)	(2198)	(3869)*	(2227)	(3111)	(2174)

Tab 10: Hubkrafttabelle EW100 – Monoausleger, Zwillingbereifung, Prätzen hinten, langer Löffelstiel

A \ B	4 m (13'-1")				5 m (16'-5")				6 m (19'-8")							
	I	II	III	IV	I	II	III	IV	I	II	III	IV	I	II	III	IV
6,0 m (19.7 ft)	2014*	2014*	2014*	2014*	-	-	-	-	-	-	-	-	2039*	2030	2039*	2025
	(4440)*	(4440)*	(4440)*	(4440)*	-	-	-	-	-	-	-	-	(4495)*	(4475)	(4495)*	(4464)
4,5 m (14.8 ft)	-	-	-	-	1815*	1514	1815*	1497	-	-	-	-	1823*	1230	1684	1209
	-	-	-	-	(4001)*	(3338)	(4001)*	(3300)	-	-	-	-	(4019)*	(2712)	(3713)	(2665)
3,0 m (9.8 ft)	2485*	2043	2485*	2039	2046*	1444	1990	1425	1827*	1077	1485	1054	1847*	1040	1423	1018
	(5478)*	(4504)	(5478)*	(4495)	(4511)*	(3183)	(4387)	(3142)	(4028)*	(2374)	(3274)	(2324)	(4072)*	(2293)	(3137)	(2244)
1,5 m (4.9 ft)	3260*	1832	2622	1820	2399*	1340	1879	1318	1959*	1028	1433	1004	1817*	921	1285	897
	(7187)*	(4039)	(5781)	(4012)	(5289)*	(2954)	(4142)	(2906)	(4319)*	(2266)	(3159)	(2213)	(4006)*	(2030)	(2833)	(1978)
0,0 m (0.0 ft)	3438*	1732	2512	1716	2525*	1271	1805	1248	1951*	992	1396	968	1849*	953	1340	929
	(7580)*	(3818)	(5538)	(3783)	(5567)*	(2802)	(3979)	(2751)	(4301)*	(2187)	(3078)	(2134)	(4076)*	(2101)	(2954)	(2048)
-1,0 m (-3.3 ft)	3190*	1725	2505	1709	2359*	1261	1794	1237	-	-	-	-	1853*	1056	1488	1031
	(7033)*	(3803)	(5523)	(3768)	(5201)*	(2780)	(3955)	(2727)	-	-	-	-	(4085)*	(2328)	(3280)	(2273)

Tab 11: Hubkrafttabelle EW100 – Monoausleger, Ballonbereifung, Prätzen hinten, kurzer Löffelstiel

A \ B	4 m (13'-1")				5 m (16'-5")				6 m (19'-8")							
	I	II	III	IV	I	II	III	IV	I	II	III	IV	I	II	III	IV
6,0 m (19.7 ft)	-	-	-	-	-	-	-	-	-	-	-	-	1824*	1716	1824*	1703
	-	-	-	-	-	-	-	-	-	-	-	-	(4021)*	(3783)	(4021)*	(3754)
4,5 m (14.8 ft)	-	-	-	-	1662*	1532	1662*	1516	-	-	-	-	1685*	1122	1539	1101
	-	-	-	-	(3664)*	(3377)	(3664)*	(3342)	-	-	-	-	(3715)*	(2474)	(3393)	(2427)
3,0 m (9.8 ft)	2274*	2077	2274*	2074	1919*	1457	1919*	1439	1729*	1082	1492	1060	1672*	923	1281	901
	(5013)*	(4579)	(5013)*	(4572)	(4231)*	(3212)	(4231)*	(3172)	(3812)*	(2385)	(3289)	(2337)	(3686)*	(2035)*	(2824)	(1986)
1,5 m (4.9 ft)	3115*	1850	2644	1839	2310*	1343	1884	1322	1899*	1024	1431	1001	1698*	856	1199	833
	(6867)*	(4079)	(5829)	(4054)	(5093)*	(2961)	(4154)	(2915)	(4187)*	(2258)	(3155)	(2207)	(3743)*	(1887)	(2643)	(1836)
0,0 m (0.0 ft)	3435*	1722	2504	1707	2508*	1261	1796	1238	1961*	979	1383	955	1738*	880	1242	856
	(7573)*	(3796)	(5520)	(3763)	(5529)*	(2780)	(3960)	(2729)	(4323)*	(2158)	(3049)	(2105)	(3832)*	(1940)	(2738)	(1887)
-1,0 m (-3.3 ft)	3276*	1701	2481	1686	2415*	1242	1775	1218	1794*	974	1377	949	1755*	962	1361	938
	(7222)*	(3750)	(5470)	(3717)	(5324)*	(2738)	(3913)	(2685)	(3955)*	(2147)	(3036)	(2092)	(3869)*	(2121)	(3000)	(2068)

Tab 12: Hubkrafttabelle EW100 – Monoausleger, Ballonbereifung, Prätzen hinten, langer Löffelstiel

Hubkrafttabellen EW100 - Verstellausleger

A B	3 m (9'-10")				4 m (13'-1")				5 m (16'-5")				6 m (19'-8")							
	I	II	III	IV	I	II	III	IV	I	II	III	IV	I	II	III	IV	I	II	III	IV
3,0 m (9.8 ft)	3130* (6902)*	3025 (6670)	3130* (6902)*	3130* (6902)*	2695* (5942)*	1830 (4035)	2695* (5942)*	2075 (4575)	2135* (4708)*	1295 (2855)	2085 (4597)	1470 (3241)	1835* (4046)*	965 (2128)	1565 (3451)	1095 (2414)	1720* (3793)*	815 (1797)	1350 (2977)	935 (2062)
1,5 m (4.9 ft)	4715* (10397)*	2600 (5733)	4505 (9934)	3015 (6648)	3280* (7232)*	1595 (3517)	2700 (5954)	1835 (4046)	2400* (5292)*	1180 (2602)	1960 (4322)	1350 (2977)	1920* (4234)*	905 (1996)	1505 (3319)	1035 (2282)	1640* (3616)*	760 (1676)	1275 (2811)	875 (1929)
0,0 m (0.0 ft)	4850* (10694)*	2330 (5138)	4195 (9250)	2735 (6031)	3225* (7111)*	1500 (3308)	2600 (5733)	1740 (3837)	2395* (5281)*	1110 (2448)	1885 (4156)	1280 (2822)	1840* (4057)*	870 (1918)	1465 (3230)	1000 (2205)	1545* (3407)*	790 (1742)	1330 (2933)	910 (2007)
-1,0 m (-3.3 ft)	3725* (8214)*	2340 (5160)	3725* (8214)*	2740 (6042)	2845* (6273)*	1500 (3308)	2600 (5733)	1740 (3837)	2145* (4730)*	1100 (2426)	1880 (4145)	1270 (2800)	1470* (3241)*	880 (1940)	1470 (3241)	1010 (2227)	1420* (3131)*	875 (1929)	1420 (3131)	1005 (2216)

Tab 13: Hubkrafttabelle EW100 – Verstellausleger, Zwillingbereifung, Planierschild hinten, kurzer Löffelstiel

A B	3 m (9'-10")				4 m (13'-1")				5 m (16'-5")				6 m (19'-8")							
	I	II	III	IV	I	II	III	IV	I	II	III	IV	I	II	III	IV	I	II	III	IV
3,0 m (9.8 ft)	-	-	-	-	2510* (5535)*	1860 (4101)	2510* (5535)*	2110 (4653)	2025* (4465)*	1305 (2878)	2025* (4465)*	1480 (3263)	1755* (3870)*	965 (2128)	1570 (3462)	1100 (2426)	1600* (3528)*	750 (1654)	1250 (2756)	860 (1896)
1,5 m (4.9 ft)	4450* (9812)*	2625 (5788)	4450* (9812)*	3040 (6703)	3180* (7012)*	1605 (3539)	2720 (5998)	1850 (4079)	2330* (5138)*	1180 (2602)	1960 (4322)	1350 (2977)	1875* (4134)*	900 (1985)	1500 (3308)	1030 (2271)	1535* (3385)*	700 (1544)	1185 (2613)	805 (1775)
0,0 m (0.0 ft)	4965* (10948)*	2285 (5038)	4150 (9151)	2685 (5920)	3260* (7188)*	1480 (3263)	2580 (5689)	1720 (3793)	2400* (5292)*	1095 (2414)	1870 (4123)	1265 (2789)	1860* (4101)*	850 (1874)	1450 (3197)	985 (2172)	1455* (3208)*	725 (1599)	1235 (2723)	835 (1841)
-1,0 m (-3.3 ft)	4085* (9007)*	2285 (5038)	4085* (9007)*	2685 (5920)	2970* (6549)*	1470 (3241)	2565 (5656)	1710 (3771)	2220* (4895)*	1075 (2370)	1850 (4079)	1245 (2745)	1645* (3627)*	845 (1863)	1445 (3186)	980 (2161)	1355* (2988)*	795 (1753)	1345 (2966)	915 (2018)

Tab 14: Hubkrafttabelle EW100 – Verstellausleger, Zwillingbereifung, Planierschild hinten, langer Löffelstiel

A B	3 m (9'-10")				4 m (13'-1")				5 m (16'-5")				6 m (19'-8")							
	I	II	III	IV	I	II	III	IV	I	II	III	IV	I	II	III	IV	I	II	III	IV
3,0 m (9.8 ft)	3130* (6902)*	2940 (6483)	3130* (6902)*	3130* (6902)*	2695* (5942)*	1775 (3914)	2695* (5942)*	2010 (4432)	2135* (4708)*	1255 (2767)	2030 (4,76)	1420 (3131)	1835* (4046)*	930 (2051)	1520 (3352)	1060 (2337)	1720* (3793)*	785 (1731)	1310 (2889)	900 (1985)
1,5 m (4.9 ft)	4715* (10397)*	2520 (5557)	4385 (9669)	2915 (6428)	3280* (7232)*	1540 (3396)	2625 (5788)	1770 (3903)	2400* (5292)*	1135 (2503)	1900 (4190)	1300 (2867)	1920* (4234)*	875 (1929)	1460 (3219)	1000 (2205)	1640* (3616)*	730 (1610)	1235 (2723)	840 (1852)
0,0 m (0.0 ft)	4850* (10694)*	2250 (4961)	4075 (8985)	2635 (5810)	3225* (7111)*	1445 (3186)	2520 (5557)	1675 (3693)	2395* (5281)*	1065 (2348)	1830 (4035)	1230 (2712)	1840* (4057)*	835 (1841)	1420 (3131)	960 (2117)	1545* (3407)*	760 (1676)	1290 (2844)	875 (1929)
-1,0 m (-3.3 ft)	3725* (8214)*	2260 (4983)	3725* (8214)*	2645 (5832)	2845* (6273)*	1445 (3186)	2520 (5557)	1675 (3693)	2145* (4730)*	1060 (2337)	1820 (4013)	1225 (2701)	1470* (3241)*	845 (1863)	1435 (3164)	975 (2150)	1420* (3131)*	840 (1852)	1420 (3131)	970 (2139)

Tab 15: Hubkrafttabelle EW100 – Verstellausleger, Ballonbereifung, Planierschild hinten, kurzer Löffelstiel

A B	3 m (9'-10")				4 m (13'-1")				5 m (16'-5")				6 m (19'-8")							
	I	II	III	IV	I	II	III	IV	I	II	III	IV	I	II	III	IV	I	II	III	IV
3,0 m (9.8 ft)	-	-	-	-	2510* (5535)*	1805 (3980)	2510* (5535)*	2045 (4509)	2025* (4465)*	1265 (2789)	2025* (4465)*	1435 (3164)	1755* (3870)*	935 (2062)	1525 (3363)	1060 (2337)	1600* (3528)*	720 (1588)	1215 (2679)	830 (1830)
1,5 m (4.9 ft)	4450* (9812)*	2545 (5612)	4415 (9735)	2945 (6494)	3180* (7012)*	1550 (3418)	2640 (5821)	1785 (3936)	2330* (5138)*	1135 (2503)	1905 (4201)	1300 (2867)	1875* (4134)*	865 (1907)	1455 (3208)	995 (2194)	1535* (3385)*	675 (1488)	1150 (2536)	775 (1709)
0,0 m (0.0 ft)	4965* (10948)*	2205 (4862)	4025 (8875)	2590 (5711)	3260* (7188)*	1425 (3142)	2505 (5524)	1660 (3660)	2400* (5292)*	1050 (2315)	1815 (4002)	1215 (2679)	1860* (4101)*	820 (1808)	1405 (3098)	945 (2084)	1455* (3208)*	695 (1532)	1195 (2635)	805 (1775)
-1,0 m (-3.3 ft)	4085* (9007)*	2200 (4851)	4025 (8875)	2585 (5700)	2970* (6549)*	1415 (3120)	2490 (5490)	1645 (3627)	2220* (4895)*	1035 (2282)	1795 (3958)	1200 (2646)	1645* (3627)*	815 (1797)	1400 (3087)	940 (2073)	1355* (2988)*	760 (1676)	1305 (2878)	880 (1940)

Tab 16: Hubkrafttabelle EW100 – Verstellausleger, Ballonbereifung, Planierschild hinten, langer Löffelstiel

Hubkrafttabellen EW100 - Verstellausleger

A \ B	3 m (9'-10")				4 m (13'-1")				5 m (16'-5")				6 m (19'-8")							
	I	II	III	IV	I	II	III	IV	I	II	III	IV	I	II	III	IV	I	II	III	IV
3,0 m (9.8 ft)	3130* (6902)*	3130* (6902)*	3130* (6902)*	3130* (6902)*	2695* (5942)*	2080 (4586)	2695* (5942)*	2175 (4796)	2135* (4708)*	1485 (3274)	2040 (4498)	1540 (3396)	1835* (4046)*	1115 (2459)	1535 (3385)	1155 (2547)	1720* (3793)*	955 (2106)	1320 (2911)	985 (2172)
1,5 m (4.9 ft)	4715* (10397)*	2985 (6582)	4410 (9724)	3165 (6979)	3280* (7232)*	1850 (4079)	2640 (5821)	1935 (4267)	2400* (5292)*	1370 (3021)	1915 (4223)	1420 (3131)	1920* (4234)*	1060 (2337)	1470 (3241)	1095 (2414)	1640* (3616)*	895 (1973)	1245 (2745)	925 (2040)
0,0 m (0.0 ft)	4850* (10694)*	2715 (5987)	4100 (9041)	2880 (6350)	3225* (7111)*	1755 (3870)	2540 (5601)	1840 (4057)	2395* (5281)*	1300 (2867)	1840 (4057)	1350 (2977)	1840* (4057)*	1020 (2249)	1435 (3164)	1060 (2337)	1545* (3407)*	930 (2051)	1300 (2867)	965 (2128)
-1,0 m (-3.3 ft)	3725* (8214)*	2725 (6009)	3725* (8214)*	2890 (6372)	2845* (6273)*	1755 (3870)	2540 (5601)	1840 (4057)	2145* (4730)*	1290 (2844)	1835 (4046)	1345 (2966)	1470* (3241)*	1030 (2271)	1445 (3186)	1070 (2359)	1420* (3131)*	1025 (2260)	1420 (3131)	1065 (2348)

Tab 17: Hubkrafttabelle EW100 – Verstellausleger, Zwillingbereifung, Pratzten vorne, Planierschild hinten, kurzer Löffelstiel

A \ B	3 m (9'-10")				4 m (13'-1")				5 m (16'-5")				6 m (19'-8")							
	I	II	III	IV	I	II	III	IV	I	II	III	IV	I	II	III	IV	I	II	III	IV
3,0 m (9.8 ft)	-	-	-	-	2510* (5535)*	2115 (4664)	2510* (5535)*	2210 (4873)	2025* (4465)*	1495 (3296)	2025* (4465)*	1555 (3429)	1755* (3870)*	1120 (2470)	1535 (3385)	1160 (2558)	1600* (3528)*	880 (1940)	1225 (2701)	910 (2007)
1,5 m (4.9 ft)	4450* (9812)*	3010 (6637)	4445* (9801)*	3190 (7034)	3180* (7012)*	1860 (4101)	2660 (5865)	1950 (4300)	2330* (5138)*	1370 (3021)	1915 (4223)	1425 (3142)	1875* (4134)*	1050 (2315)	1465 (3230)	1090 (2403)	1535* (3385)*	825 (1819)	1160 (2558)	855 (1885)
0,0 m (0.0 ft)	4965* (10948)*	2670 (5887)	4055 (8941)	2840 (6262)	3260* (7188)*	1735 (3826)	2520 (5557)	1820 (4013)	2400* (5292)*	1285 (2833)	1825 (4024)	1335 (2944)	1860* (4101)*	1005 (2216)	1415 (3120)	1040 (2293)	1455* (3208)*	855 (1885)	1205 (2657)	885 (1951)
-1,0 m (-3.3 ft)	4085* (9007)*	2670 (5887)	4050 (8930)	2835 (6251)	2970* (6549)*	1725 (3804)	2510 (5535)	1805 (3980)	2220* (4895)*	1265 (2789)	1810 (3991)	1320 (2911)	1645* (3627)*	1000 (2205)	1410 (3109)	1035 (2282)	1355* (2988)*	935 (2062)	1315 (2900)	970 (2139)

Tab 18: Hubkrafttabelle EW100 – Verstellausleger, Zwillingbereifung, Pratzten vorne, Planierschild hinten, langer Löffelstiel

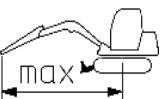
A \ B	3 m (9'-10")				4 m (13'-1")				5 m (16'-5")				6 m (19'-8")							
	I	II	III	IV	I	II	III	IV	I	II	III	IV	I	II	III	IV	I	II	III	IV
3,0 m (9.8 ft)	3130* (6902)*	3130* (6902)*	3130* (6902)*	3130* (6902)*	2695* (5942)*	2025 (4465)	2695* (5942)*	2110 (4653)	2135* (4708)*	1445 (3186)	1985 (4377)	1495 (3296)	1835* (4046)*	1080 (2381)	1490 (3285)	1115 (2459)	1720* (3793)*	925 (2040)	1280 (2822)	950 (2095)
1,5 m (4.9 ft)	4715* (10397)*	2900 (6395)	4290 (9459)	3065 (6758)	3280* (7232)*	1790 (3947)	2565 (5656)	1870 (4123)	2400* (5292)*	1325 (2922)	1860 (4101)	1375 (3032)	1920* (4234)*	1025 (2260)	1430 (3153)	1055 (2326)	1640* (3616)*	865 (1907)	1205 (2657)	890 (1962)
0,0 m (0.0 ft)	4850* (10694)*	2630 (5799)	3980 (8776)	2785 (6141)	3225* (7111)*	1700 (3749)	2460 (5424)	1775 (3914)	2395* (5281)*	1255 (2767)	1785 (3936)	1305 (2878)	1840* (4057)*	985 (2172)	1390 (3065)	1020 (2249)	1545* (3407)*	900 (1985)	1260 (2778)	930 (2051)
-1,0 m (-3.3 ft)	3725* (8214)*	2640 (5821)	3725* (8214)*	2795 (6163)	2845* (6273)*	1700 (3749)	2465 (5435)	1775 (3914)	2145* (4730)*	1250 (2756)	1780 (3925)	1295 (2855)	1470* (3241)*	1000 (2205)	1400 (3087)	1030 (2271)	1420* (3131)*	995 (2194)	1390 (3065)	1025 (2260)

Tab 19: Hubkrafttabelle EW100 – Verstellausleger, Ballonbereifung, Pratzten vorne, Planierschild hinten, kurzer Löffelstiel

A \ B	3 m (9'-10")				4 m (13'-1")				5 m (16'-5")				6 m (19'-8")							
	I	II	III	IV	I	II	III	IV	I	II	III	IV	I	II	III	IV	I	II	III	IV
3,0 m (9.8 ft)	-	-	-	-	2510* (5535)*	2060 (4542)	2510* (5535)*	2145 (4730)	2025* (4465)*	1455 (3208)	2000 (4410)	1505 (3319)	1755* (3870)*	1085 (2392)	1495 (3296)	1120 (2470)	1600* (3528)*	850 (1874)	1185 (2613)	880 (1940)
1,5 m (4.9 ft)	4450* (9812)*	2925 (6450)	4325 (9537)	3095 (6824)	3180* (7012)*	1805 (3980)	2585 (5700)	1885 (4156)	2330* (5138)*	1325 (2922)	1860 (4101)	1375 (3032)	1875* (4134)*	1020 (2249)	1425 (3142)	1050 (2315)	1535* (3385)*	800 (1764)	1120 (2470)	825 (1819)
0,0 m (0.0 ft)	4965* (10948)*	2585 (5700)	3935 (8677)	2740 (6042)	3260* (7188)*	1680 (3704)	2445 (5391)	1755 (3870)	2400* (5292)*	1240 (2734)	1770 (3903)	1290 (2844)	1860* (4101)*	970 (2139)	1370 (3021)	1005 (2216)	1455* (3208)*	825 (1819)	1165 (2569)	855 (1885)
-1,0 m (-3.3 ft)	4085* (9007)*	2585 (5700)	3930 (8666)	2735 (6031)	2970* (6549)*	1670 (3682)	2430 (5358)	1740 (3837)	2220* (4895)*	1225 (2701)	1750 (3859)	1270 (2800)	1645* (3627)*	965 (2128)	1365 (3010)	1000 (2205)	1355* (2988)*	905 (1996)	1275 (2811)	935 (2062)

Tab 20: Hubkrafttabelle EW100 – Verstellausleger, Ballonbereifung, Pratzten vorne, Planierschild hinten, langer Löffelstiel

Hubkrafttabellen EW100 - Verstellausleger

A \ B	3 m (9'-10")				4 m (13'-1")				5 m (16'-5")				6 m (19'-8")							
	I	II	III	IV	I	II	III	IV	I	II	III	IV	I	II	III	IV	I	II	III	IV
3,0 m (9.8 ft)	3130* (6902)*	3070 (6769)	3130* (6902)*	3130* (6902)*	2695* (5942)*	1860 (4101)	2695* (5942)*	2045 (4509)	2135* (4708)*	1320 (2911)	2005 (4421)	1445 (3186)	1835* (4046)*	980 (2161)	1505 (3319)	1075 (2370)	1720* (3793)*	835 (1841)	1290 (2844)	915 (2018)
1,5 m (4.9 ft)	4715* (10397)*	2650 (5843)	4335 (9559)	2965 (6538)	3280* (7232)*	1625 (3583)	2595 (5722)	1800 (3969)	2400* (5292)*	1200 (2646)	1880 (4145)	1325 (2922)	1920* (4234)*	925 (2040)	1445 (3186)	1020 (2249)	1640* (3616)*	775 (1709)	1220 (2690)	855 (1885)
0,0 m (0.0 ft)	4850* (10694)*	2380 (5248)	4025 (8875)	2680 (5909)	3225* (7111)*	1530 (3374)	2490 (5490)	1705 (3760)	2395* (5281)*	1130 (2492)	1805 (3980)	1255 (2767)	1840* (4057)*	885 (1951)	1405 (3098)	980 (2161)	1545* (3407)*	810 (1786)	1275 (2811)	890 (1962)
-1,0 m (-3.3 ft)	3725* (8214)*	2390 (5270)	3725* (8214)*	2690 (5931)	2845* (6273)*	1530 (3374)	2490 (5490)	1705 (3760)	2145* (4730)*	1125 (2481)	1800 (3969)	1245 (2745)	1470* (3241)*	900 (1985)	1415 (3120)	990 (2183)	1420* (3131)*	895 (1973)	1405 (3098)	985 (2172)

Tab 21: Hubkrafttabelle EW100 – Verstellausleger, Zwillingbereifung, Prätzen hinten, kurzer Löffelstiel

A \ B	3 m (9'-10")				4 m (13'-1")				5 m (16'-5")				6 m (19'-8")							
	I	II	III	IV	I	II	III	IV	I	II	III	IV	I	II	III	IV	I	II	III	IV
3,0 m (9.8 ft)	-	-	-	-	2510* (5535)*	1895 (4178)	2510* (5535)*	2080 (4586)	2025* (4465)*	1330 (2933)	2020* (4454)	1455 (3208)*	1755* (3870)*	985 (2217)	1510 (3330)	1080 (2381)	1600* (3528)*	765 (1687)	1200 (2646)	845 (1863)
1,5 m (4.9 ft)	4450* (9812)*	2675 (5898)	4365 (9625)	2990 (6593)	3180* (7012)*	1640 (3616)	2610 (5755)	1820 (4013)	2330* (5138)*	1200 (2646)	1880 (4145)	1325 (2922)	1875* (4134)*	920 (2029)	1440 (3175)	1010 (2227)	1535* (3385)*	715 (1577)	1135 (2503)	790 (1742)
0,0 m (0.0 ft)	4965* (10948)*	2335 (5149)	3975 (8765)	2635 (5810)	3260* (7188)*	1515 (3341)	2475 (5457)	1690 (3726)	2400* (5292)*	1115 (2459)	1790 (3947)	1240 (2734)	1860* (4101)*	870 (1918)	1390 (3065)	965 (2128)	1455* (3208)*	740 (1632)	1180 (2602)	820 (1808)
-1,0 m (-3.3 ft)	4085* (9007)*	2335 (5149)	3975 (8765)	2635 (5810)	2970* (6549)*	1500 (3308)	2460 (5424)	1675 (3693)	2220* (4895)*	1100 (2426)	1775 (3914)	1220 (2690)	1645* (3627)*	865 (1907)	1385 (3054)	960 (2117)	1355* (2988)*	810 (1786)	1285 (2833)	895 (1973)

Tab 22: Hubkrafttabelle EW100 – Verstellausleger, Zwillingbereifung, Prätzen hinten, langer Löffelstiel

A \ B	3 m (9'-10")				4 m (13'-1")				5 m (16'-5")				6 m (19'-8")							
	I	II	III	IV	I	II	III	IV	I	II	III	IV	I	II	III	IV	I	II	III	IV
3,0 m (9.8 ft)	3130* (6902)*	2990 (6593)	3130* (6902)*	3130* (6902)*	2695* (5942)*	1805 (3980)	2695* (5942)*	1980 (4366)	2135* (4708)*	1275 (2811)	1950 (4300)	1395 (3076)	1835* (4046)*	950 (2095)	1460 (3219)	1040 (2293)	1720* (3793)*	805 (1775)	1255 (2767)	880 (1940)
1,5 m (4.9 ft)	4715* (10397)*	2565 (5656)	4210 (9283)	2865 (6317)	3280* (7232)*	1570 (3462)	2515 (5546)	1740 (3837)	2400* (5292)*	1160 (2558)	1825 (4024)	1275 (2811)	1920* (4234)*	890 (1962)	1400 (3087)	980 (2161)	1640* (3616)*	745 (1643)	1180 (2602)	825 (1819)
0,0 m (0.0 ft)	4850* (10694)*	2295 (5060)	3900 (8600)	2585 (5700)	3225* (7111)*	1475 (3252)	2415 (5325)	1640 (3616)	2395* (5281)*	1090 (2403)	1750 (3859)	1205 (2657)	1840* (4057)*	855 (1885)	1360 (2999)	940 (2073)	1545* (3407)*	780 (1720)	1235 (2723)	855 (1885)
-1,0 m (-3.3 ft)	3725* (8214)*	2305 (5083)	3725* (8214)*	2595 (5722)	2845* (6273)*	1475 (3,252)	2390 (5270)	1640 (3616)	2145* (4730)*	1085 (2392)	1740 (3837)	1200 (2646)	1470* (3241)*	865 (1907)	1370 (3021)	955 (2106)	1420* (3131)*	860 (1896)	1365 (3010)	950 (2095)

Tab 23: Hubkrafttabelle EW100 – Verstellausleger, Ballonbereifung, Prätzen hinten, kurzer Löffelstiel

A \ B	3 m (9'-10")				4 m (13'-1")				5 m (16'-5")				6 m (19'-8")							
	I	II	III	IV	I	II	III	IV	I	II	III	IV	I	II	III	IV	I	II	III	IV
3,0 m (9.8 ft)	-	-	-	-	2510 (5535)	1840 (4057)	2510 (5535)	2015 (4443)	2025 (4465)	1290 (2844)	1960 (4322)	1410 (3109)	1755 (3870)	950 (2095)	1465 (3230)	1040 (2293)	1600 (3528)	740 (1632)	1160 (2558)	810 (1786)
1,5 m (4.9 ft)	4450* (9812)*	2590 (5711)	4245 (9360)	2890 (6372)	3180 (7012)	1585 (3495)	2535 (5590)	1755 (3870)	2330 (5138)	1160 (2558)	1825 (4024)	1275 (2811)	1875 (4134)	885 (1951)	1395 (3076)	975 (2150)	1535 (3385)	690 (1521)	1100 (2426)	760 (1676)
0,0 m (0.0 ft)	4965* (10948)*	2250 (4961)	3855 (8500)	2540 (5601)	3260 (7188)	1460 (3219)	2395 (5281)	1625 (3583)	2400 (5292)	1075 (2370)	1735 (3826)	1190 (2624)	1860 (4101)	835 (1841)	1345 (2966)	925 (2040)	1455 (3208)	710 (1566)	1140 (2514)	785 (1731)
-1,0 m (-3.3 ft)	4085* (9007)*	2250 (4961)	3850 (8489)	2535 (5590)	2970 (6549)	1445 (3186)	2380 (5248)	1610 (3550)	2220 (4895)	1060 (2337)	1715 (3782)	1175 (2591)	1645 (3627)	830 (1830)	1340 (2955)	920 (2029)	1355 (2988)	780 (1720)	1245 (2745)	860 (1896)

Tab 24: Hubkrafttabelle EW100 – Verstellausleger, Ballonbereifung, Prätzen hinten, langer Löffelstiel